

Senator Technology

E-line 78 & 92

Compact. Strong. Efficient.



SCHNEIDER
SENATOR

Cutting Technology

Gruppe Maschinenrahmen

SCHNEIDER
SENATOR

Small size,

High-speed cutter Senator E-Line 78 & 92

Small format cutting requires flawless precision and reliability: the new Senator E-Line. This highspeed guillotine for cutting widths of 78 cm and 92 cm provides all the quality advantages Schneider Senator is renowned for – at an unbeatable price.



The E-Line is fully equipped.

- High-speed cutter Senator E-Line 78 and 92 with mechanical knife drive and hydraulic clamp
- Computer-control with TFT-colour monitor
- Frequency-controlled backgauge drive, ball race lead screw
- Closed rear table
- Solid cast iron frame
- Infrared safety curtain
- CE & EN 1010 - conform
- Safety bolt
- Airfilm table with stainless steel surface, rust-proof
- Side tables, left- and righthand side, each with airfilm and stainless steel surface, rust-proof
- Optical cut indicator
- Knife change and knife adjustments at the front of the machine
- 2 knives
- 5 sinus cutting sticks
- Clamp cover plate
- Tools
- Colour: RAL 7035, light grey

Proven technique – logically consistent development.

At Schneider Senator we're proud of our decades of experience in manufacturing guillotines for every cutting width. We know that a highspeed guillotine must be able to provide problem free performance under non stop working conditions. That's why our E-Line machines are designed around a solid cast iron frame. Longevity is guaranteed by a proven mechanical / hydraulic construction. In most cases an E-Line guillotine doesn't need to be anchored to the shop floor. Its direct power drive requires no clutch, flywheel or similar wearing parts. As a result, it is exceptionally dependable and energy efficient. The Senator E-Line is ideal for small printing shops requiring reliable, non-stop performance.

During the development phase of the E-Line, we took great pains to ensure user-friendly operations. Knife changes, for example, can be performed easily and quickly without the operator having to leave his station. The knife adjustment is located at the front

of the machine. The knife draw rod never needs to be adjusted. All grease nipples are located at the outside of the machine. The standard stainless steel airfilm side tables make working with the E-Line a breeze. They are a great asset when it comes to handling heavy stock.

The heart of the E-Line is the computer-control in type 'C' (5' TFT-colour monitor), type 'CP' (10,4' TFT-colour monitor) or type 'CT' (10,4' TFT-touch-screen colour-monitor). It has been developed inhouse exclusively for our guillotines. The ergonomically designed keyboard puts the easy to understand icons within easy reach. Its capacity with 5700 steps and unlimited number of programmes is more than you'll ever need. The service diagnostic program, as well as the fully automatic repeat cut function are standard. Learning how to operate this problem free machine is exceptionally easy. After all, we know what you want: flexibility, not headaches.

big performance.

E-line

Everything under control: The computer-control

Different control types	'C'	'CP'	'CT'
TFT-colour monitor	5"	10,4"	10,4"
Alphanumeric flat-foil keyboard with logical key blocks and mechanical pressure point keys	x	x	x
Touch-screen soft keys			x
Memory capacity: 5,700 steps	5.700 steps	5.700 steps	5.700 steps
Number of programmes	unlimited ¹⁾	unlimited ¹⁾	unlimited ¹⁾
Diverse-redundant cutting system (two independent, mutually verifying microprocessors)	x	x	x
Graphic display of the programme flow			x
Incorrect cut control (no cut release when position tolerance is exceeded)	x	x	x
Execution of desired dimensions, without disturbing the original programme	x	x	x
Measuring system: inches / mm / cm	x	x	x
Indication of free storing spaces	x	x	x
Measurement precision: 1/100 mm	x	x	x
Service cut counter	x	x	x
Programmable cut counter	x	x	x
Air on/off	x	x	x
Fault diagnosis	x	x	x
Calculator function	x	x	x
Time and date display	x	x	x
Programme erase protection	x	x	x
Data protection in case of power failure	x	x	x
Language selection	x	x	x
IC-memory-card			x
CIP 3/4-compatible (automatic generating of cutting programmes from pre-press data)			x ²⁾
Serial interface			x ²⁾
Logging the operational data			x ²⁾
Printer port			x ²⁾
Programming options:			
Simple cut, repeat cut, programme cut	x	x	x
Digitally adjustable pre-press time	x	x	x
Differential measurement	x	x	x
Programming by value input or actual transmission	x	x	x
Infinitely variable backgauge speed	x	x	x
Function "no cut"	x	x	x
Linear programme correction facility	x	x	x
Percentagewise programme correction facility			x
Automatic paper ejection and programmable paper ejection marks	x	x	x
Operator information programmable			x
Cut optimizer			x
External functions, external programming			x

¹⁾ Only limited by max. steps to be stored , ²⁾ option

High-speed cutter Senator E-Line 78 & 92

E-line

Technical Data

78

92

A	Cutting width, mm / inch	780 / 30,71	920 / 36,22
B	Feed depth, mm / inch	780 / 30,71	920 / 36,22
C	Clamp opening, mm / inch	120 / 4,72	120 / 4,72
D	Table height, mm / inch	900 / 35,43	900 / 35,43
E	Machine width, mm / inch - without side tables	1.640 / 64,57	1.700 / 66,93
F	Machine width, mm / inch - including side tables	1.719 / 67,68	1.835 / 72,24
G	Machine depth, mm / inch	1.811 / 71,30	1.992 / 78,43
H	Machine height, mm / inch	1.565 / 61,61	1.520 / 59,84
I	Front table length, mm / inch	657 / 25,87	657 / 25,87
K	Side table depth, mm / inch	471 / 18,54	471 / 18,54
L	Side table width, mm / inch	436 / 17,17	436 / 17,17
	Power required (main drive), max. kW	3,8	5,5
	Weight net, kg / lbs	1.400 / 3.084	1.600 / 3.525
	Clamp pressure min., daN	150	180
	max., daN	2.500	3.000
	Knife thickness, mm / inch	12 / 0,47	12 / 0,47
	Smallest cut, mm / inch - with false clamp plate	65 / 2,56	80 / 3,15
	Smallest cut, mm / inch - without false clamp plate	20 / 0,79	25 / 0,98
	Backgauge speed, mm/s / inch/s	225 / 8,86	225 / 8,86

Subject to technical modifications. Errors excepted.

Measurements

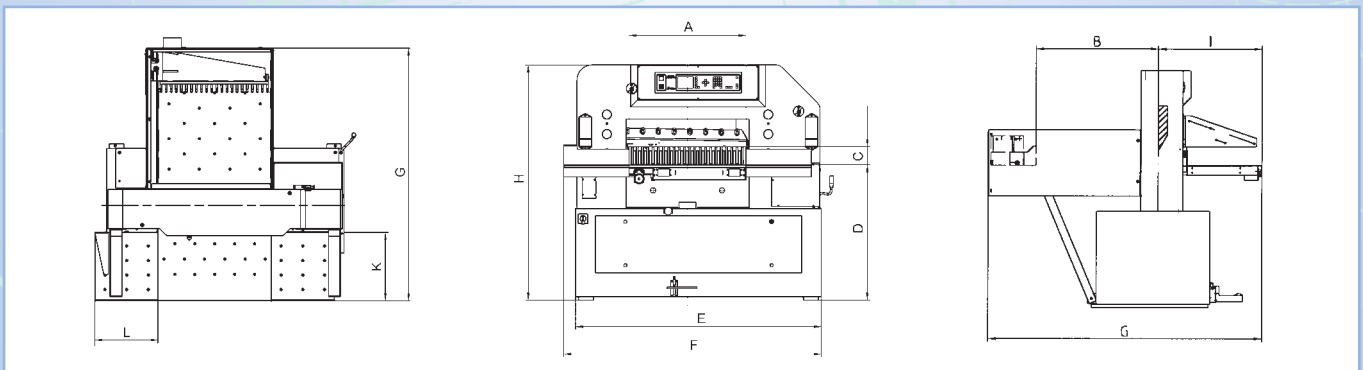

SCHNEIDER SENATOR

Cutting Technology

Printed in Germany, 03.2006