

# Perfetto Compensating Stacker

## Specifications



<b>Maximum mechanical speed</b>	16,000 cycles per hour	
<b>Product size range</b>	(mm)	(in ″)
	A maximum	480
	A minimum	148
	B maximum	330
	B minimum	105
	C maximum	20
	C minimum	8 pages
	or 400 pages	
<b>Layer compartment height</b>	150 mm	5 7/8
<b>Stack height, max.</b>	250 mm (9 7/8″) standard	350 mm (13 3/4″) optional
<b>Electrical power requirements</b>	Stacker incl. control system	2 kW
	extra per belt delivery	0,25 kW
<b>Compressed air consumption</b>	6 bar	8 Nm <sup>3</sup> /h (5 cfm at 90 psi)
<b>Weight</b>	900 kg (1,980 lbs)	
<b>Cycle time</b>	Single-sided ejection	1,5 sec. at an ejection speed of 0,6 m/s (2 ft/sec.)
	Alternate delivery	1,1 sec. at an ejection speed of 0,6 m/s (2 ft/sec.)

Dimensions, design and equipment configuration subject to change.

- 1 Infeed belt
- 2 Perfetto Compensating Stacker, Model 450
- 3 Belt section
- 4 Roller delivery
- 5 Air table Model 248
- 6 Optional Eltex electrostatic charging

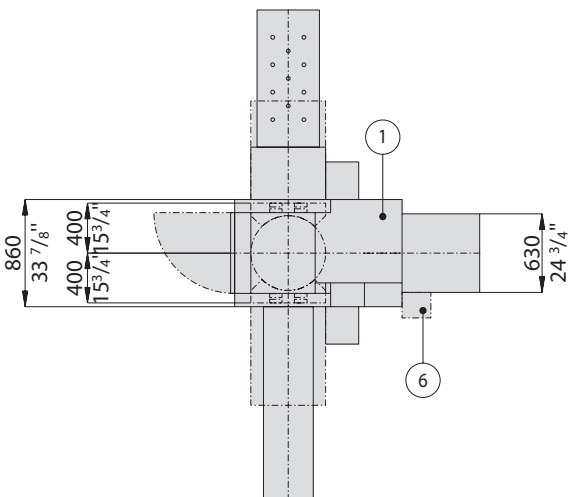
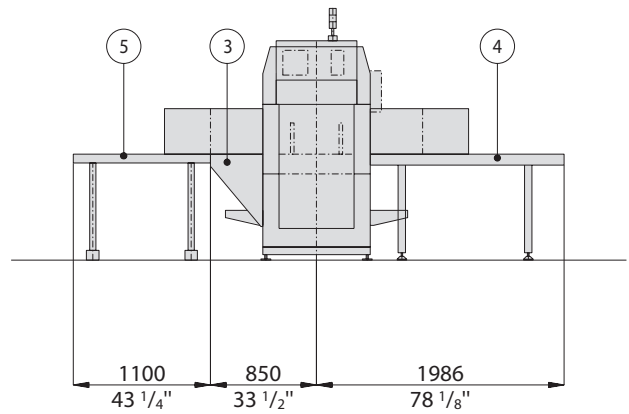
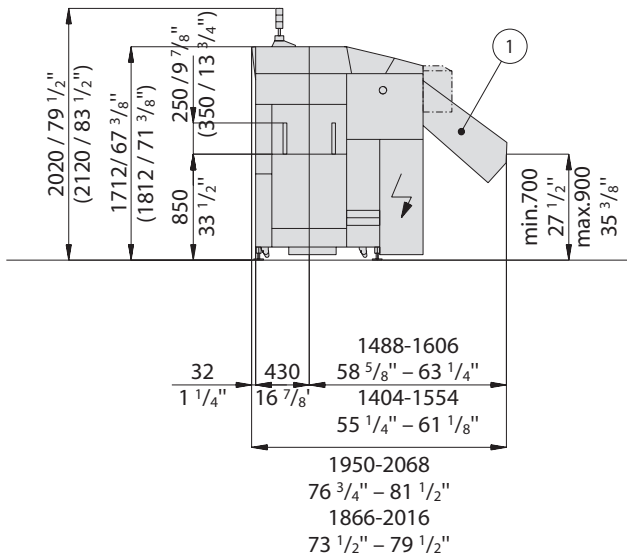

Sales and service

Müller Martini Marketing AG  
 Untere Brühlstrasse 13  
 CH-4800 Zofingen, Switzerland  
 Phone +41 (0)62 745 45 75  
 Fax +41 (0)62 751 55 50  
 info@mullermartini.com  
 www.mullermartini.com