

Your strong partner.

Perfect Binder Pantera.

The compact Allrounder for economical Perfect Binding.

MÜLLER MARTINI





USP's / Key Advantages of the Pantera.

- **Most compact perfect binder in the class up to 4000 c/hr**
 - ▶ The binder measures less than 8m in length and less than 2m in width
- **Top Quality of the bound book and the machine itself**
 - ▶ Hotmelt and PUR adhesive technology, drum cover feeder
- ***The ideal Perfect Binder – for Offset and Digital print products***
 - ▶ *Run lengths from 10 – 10'000 units/order*
- **Modularity and flexibility in perfection**
 - ▶ From the stand-alone version with hand-feed station it is expandable up to a complete in-line binding system with gathering machine, conveyors and three-knife trimmer



MÜLLER MARTINI



Key features at a glance.

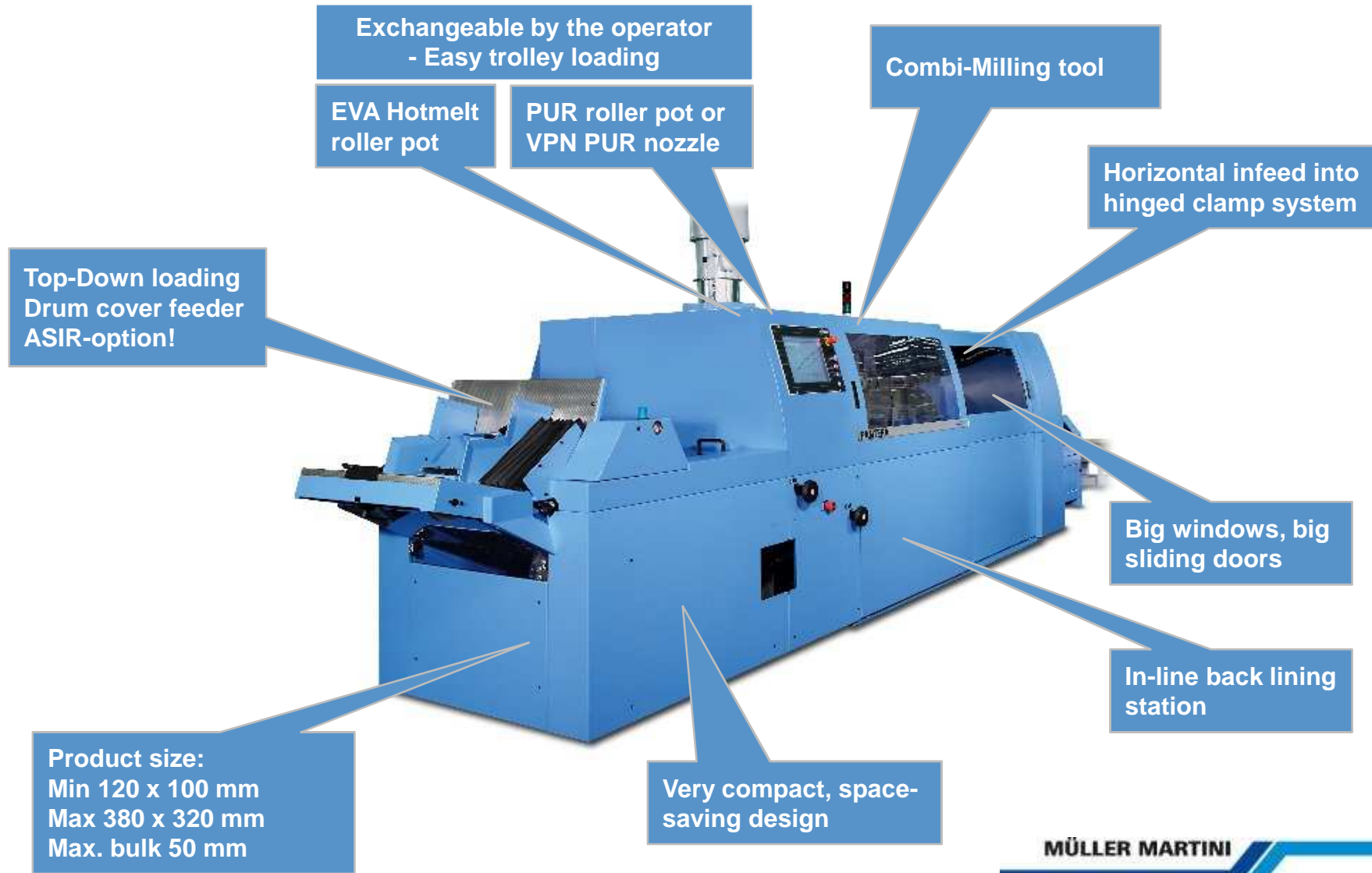



Key features at a glance.

Operation via proven MM Commander

- ▶ 15" Touchscreen with simple and intuitive interface
- ▶ Operator has all important production parameters on hand and fast access to all work stations
- ▶ The intuitive operator interface allows for extremely fast change-over times and production start times
- ▶ Easy handling of repetitive jobs thanks to integrated data storage
- ▶ Identical concept on all Müller Martini machines

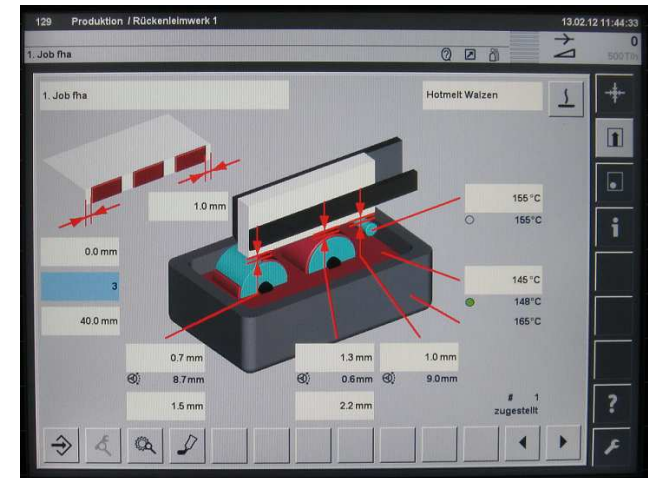



Key features at a glance.

Modern line control concept

- ▶ Transparent line control and line overview on central Commander
- ▶ Fast changeover with Book Data Center BDC
- ▶ Display of the visualisation of all line aggregates: gatherer 3692, perfect binder, conveyors and three-knife trimmer
- ▶ Completely networked binding line, messages and warnings of the entire line are displayed
- ▶ Operator input, fine corrections are possible at any time



Gathering machine

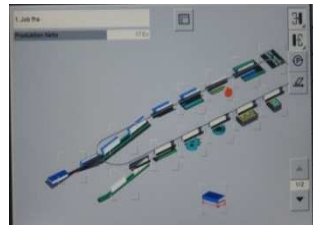

Perfect Binder

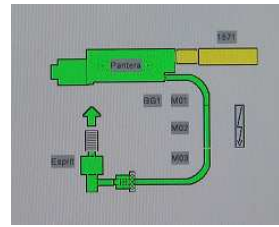

Conveyors

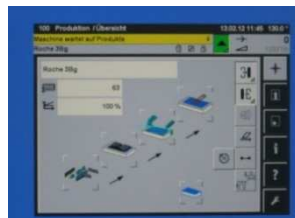

Trimmer

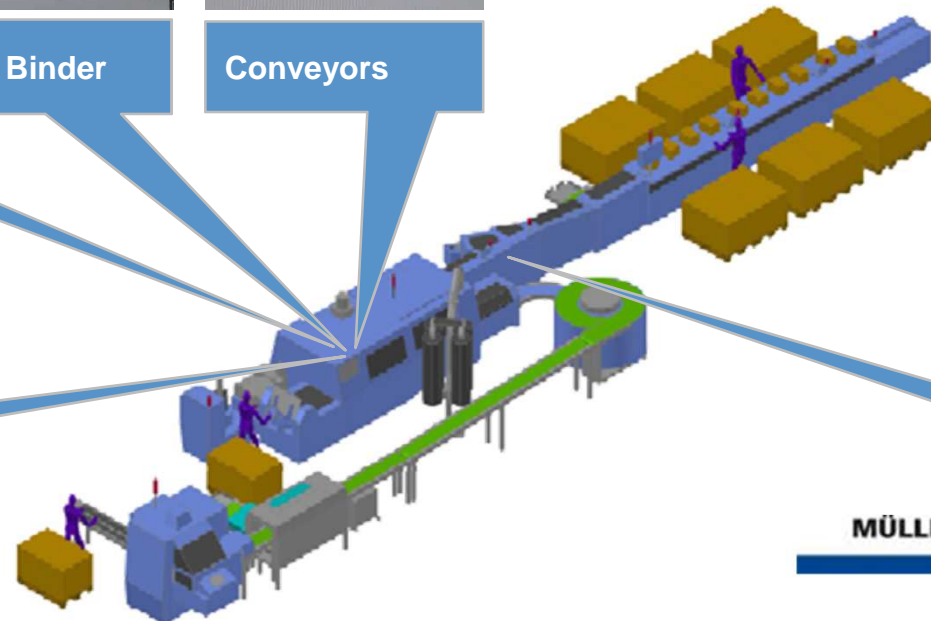

Book Data Center

MÜLLER MARTINI



Key features at a glance.

Hinge clamps

- ▶ Ideal for smooth product transfer into clamp
- ▶ Automatic thickness setting
- ▶ Pressing force generated by torsion springs
- ▶ Maintenance-free
- ▶ Quick opening mechanism without tool or force



Spine preparation stations

- ▶ Main milling station and one spine preparation station
- ▶ Milling and roughening tools (notching, roughening, brushing)
- ▶ Quick lowering for production of thread sewn books including press function immediately prior to gluing



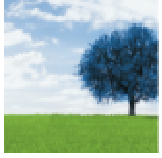

Key features at a glance.

Exchangeable glue stations

- ▶ EVA Hotmelt roller, PUR roller and PUR nozzle stations are interchangeable by the operator
- ▶ Electronic adjustable glue film length via Commander during production
- ▶ Optimized pot design, minimal energy use, spot gluing capability
- ▶ Exchangeable side glue discs
- ▶ MOD Technology and fast exchange thanks to pre-heating station and movable glue stations
- ▶ Nozzle system VPN-6, glue refill without machine stop

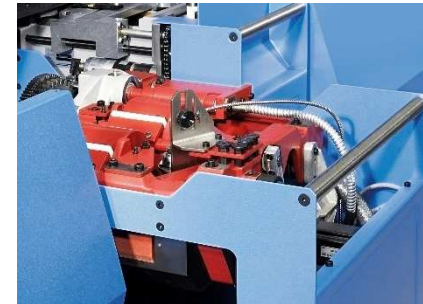
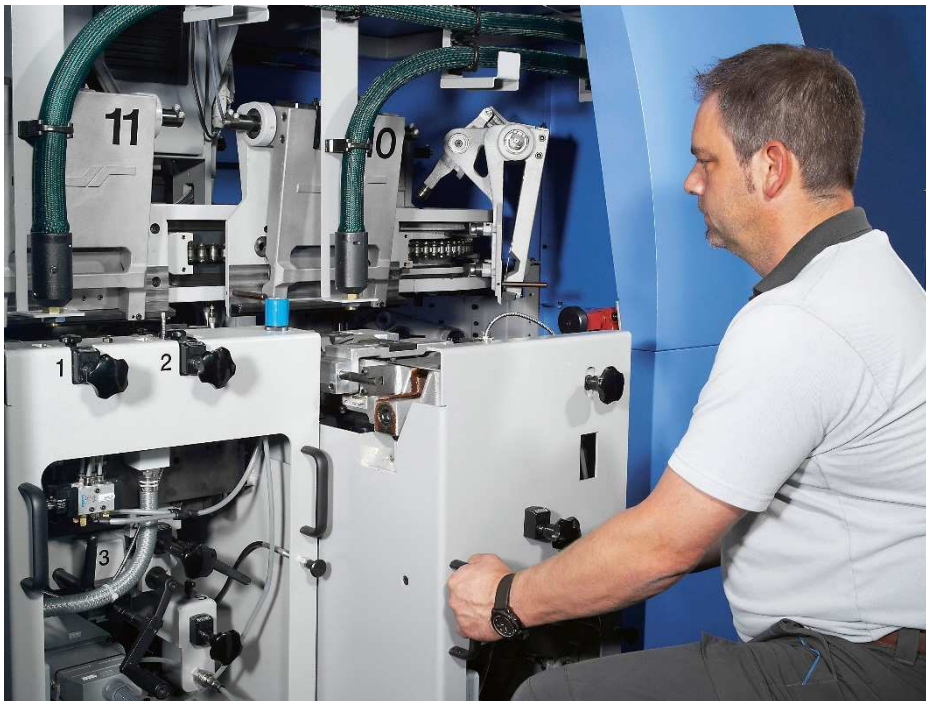

MÜLLER MARTINI



Key features at a glance.

Top-Down Cover feeder

- ▶ Drum cover feeder with large loading capacity
- ▶ Ergonomic loading height
- ▶ Large drum diameter for flexible and secure processing of various formats and covers with flaps
- ▶ Low pile detection and warning
- ▶ Cover title can be seen during loading, prevents incorrect feeding due to unprinted inside cover

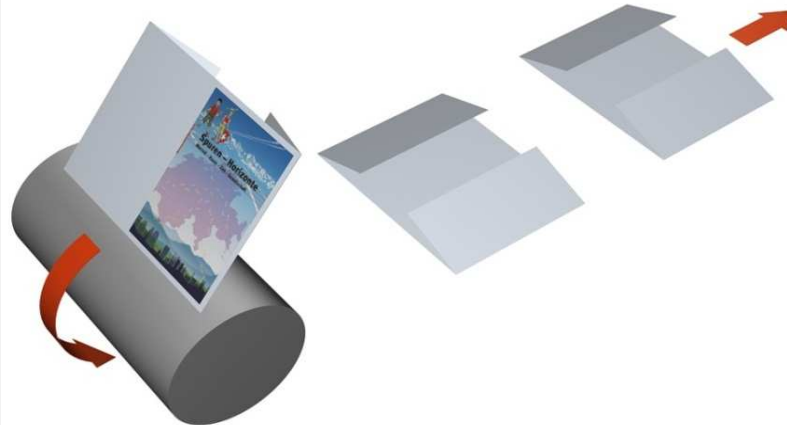



Key features at a glance.

Quality control: ASIR as a concept for error-free finishing production!

- ▶ Guarantees correct product-assembly by means of book verification system
- ▶ AsirCode prevents a production start with incorrectly loaded signatures and cover.

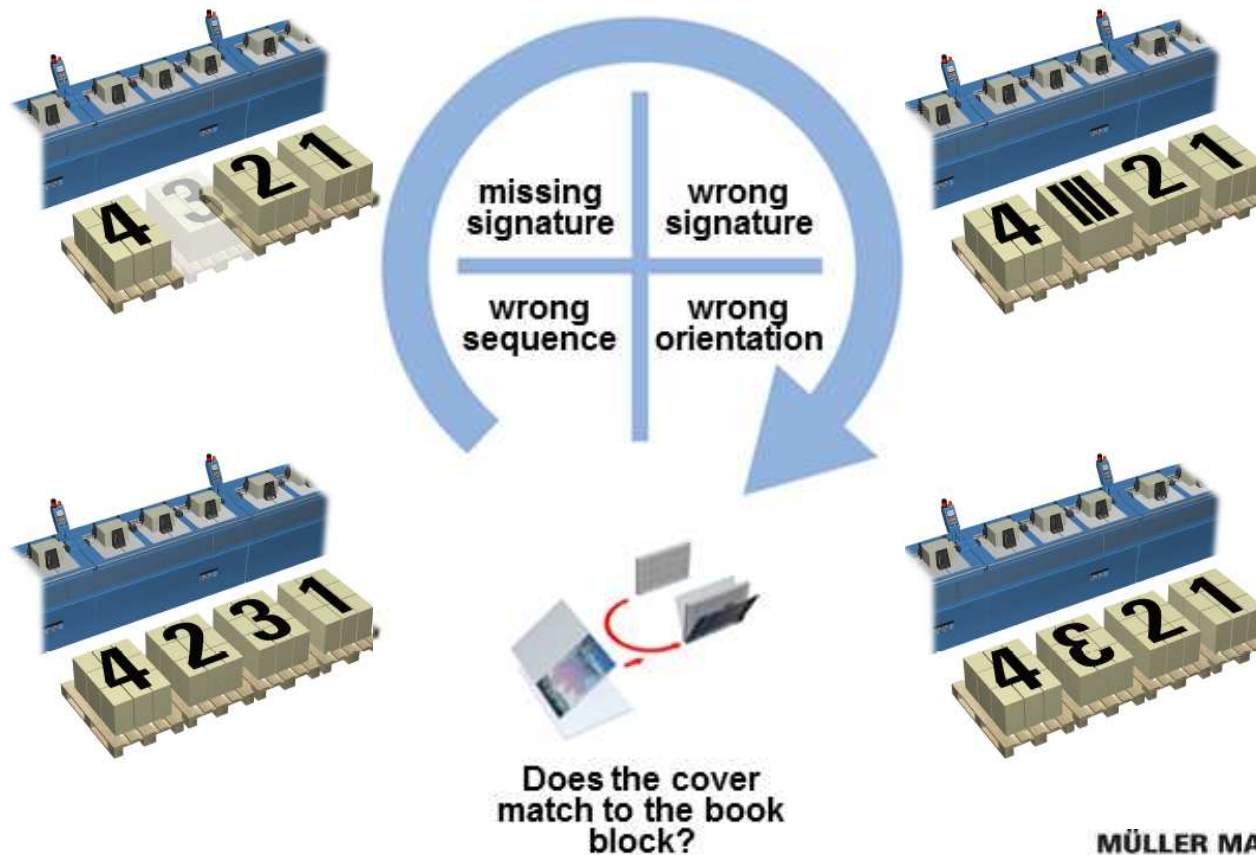



Key features at a glance.

Lining station

- ▶ Lengthwise feeding of lining material
- ▶ Precise positioning of the lining material via vacuum application roller
- ▶ Tool-less roll change thanks to quick tensioning device
- ▶ Processing of layflat brochures (in two passes)

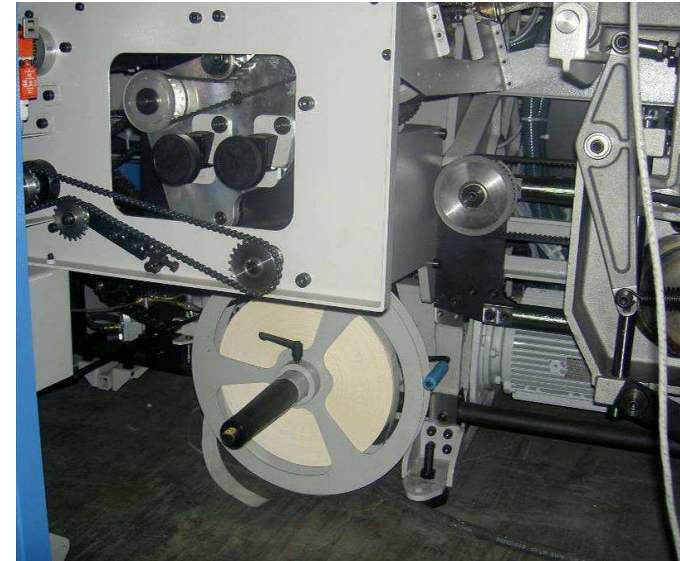



Key features at a glance.

Gathering Machine 3692

- ▶ Ideal addition to the Pantera
- ▶ Reliable and proven drum principle with flat raceway channel
- ▶ Quick, menu-guided set-up
- ▶ Feeding and operation from both sides
- ▶ Raceway channel access from left and right side
- ▶ Automatic, self-calibrating thickness detection “Asac”
- ▶ Sequential start and stop
- ▶ Asir 3, optical picture or barcode recognition
- ▶ Optional CrissCross Delivery



MÜLLER MARTINI



Key features at a glance.

Best in class: Three-Knife Trimmer Granit

- ▶ Ideal solution to Pantera
- ▶ SmartPress Technology for perfect cut quality
- ▶ Large format range
- ▶ Swing-pull cut
- ▶ Massive, single-piece casting
- ▶ Up to 2'500 c/hr



High initial approach speed



Reduction of speed

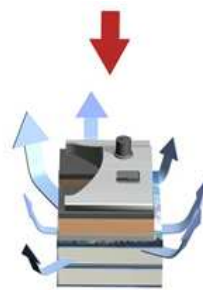

Air escapes thanks to smooth pressing. Optimal pressing of the book block by increasing pressing force just prior to the cut



MÜLLER MARTINI



Key features at a glance – Modular Design.

Modularity and flexibility in perfection

- ▶ Pantera – As solo-machine with hand-feed station

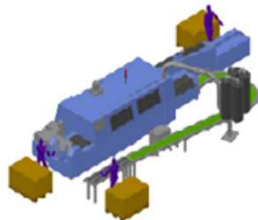
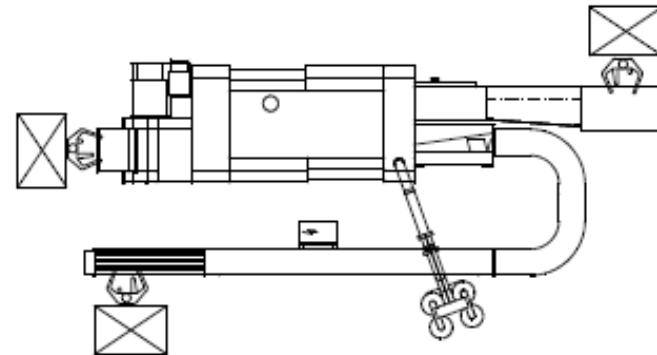



Key features at a glance – Modular Design.

Modularity and flexibility in perfection

- ▶ Pantera – in-line with gathering machine 3692 and reject gate

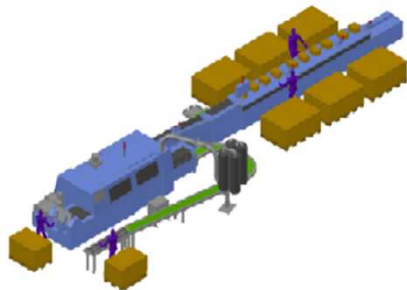
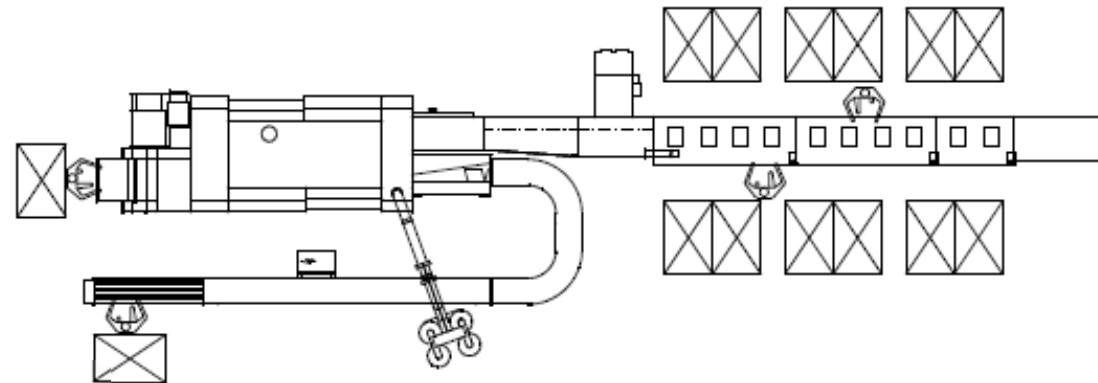



Key features at a glance – Modular Design.

Modularity and flexibility in perfection

- ▶ Pantera – in-line with gathering machine 3692 and Criss Cross delivery

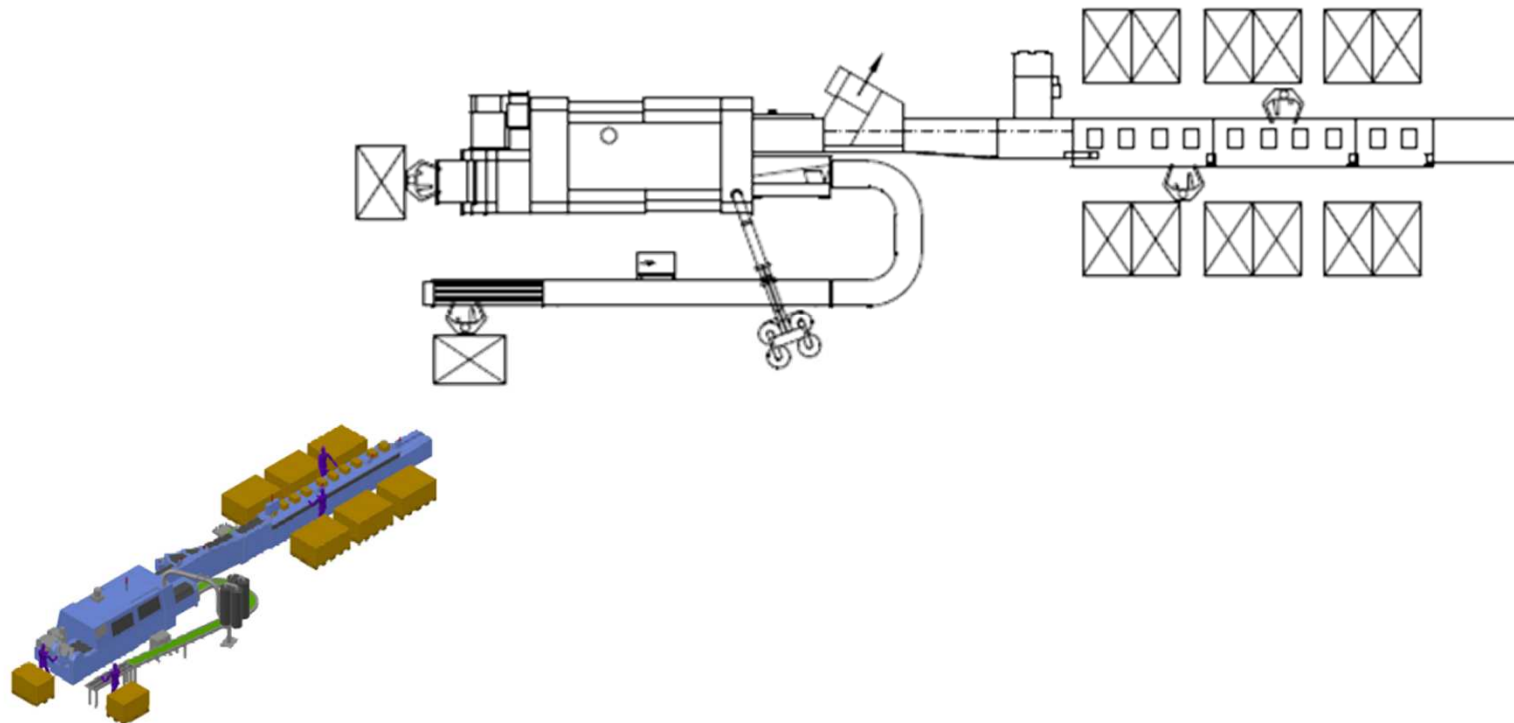



Key features at a glance – Modular Design.

Modularity and flexibility in perfection

- ▶ Pantera – In-line with gathering machine 3692 and three-knife trimmer Granit complete for Hotmelt production

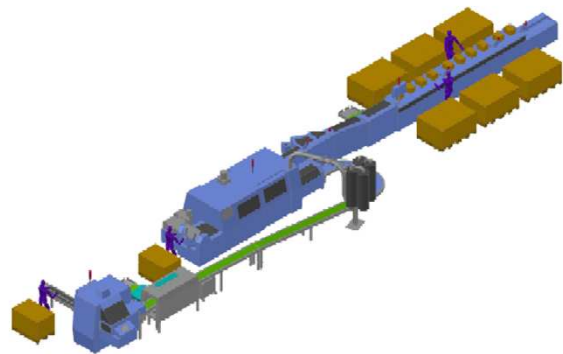
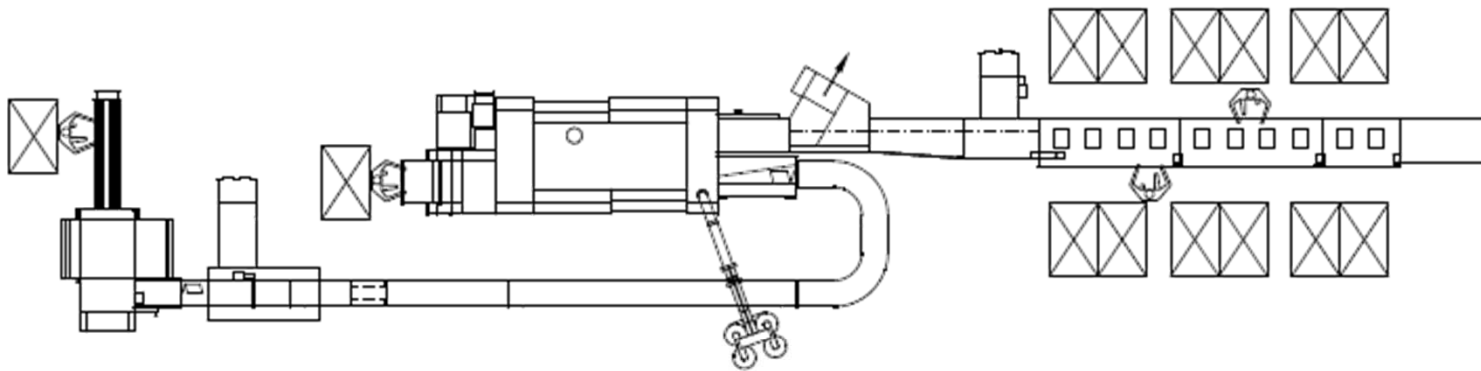



Key features at a glance – Modular Design.

Modularity and flexibility in perfection

- ▶ Pantera – in-line with gathering machine 3692 and three-knife trimmer Granit complete for PUR-Production

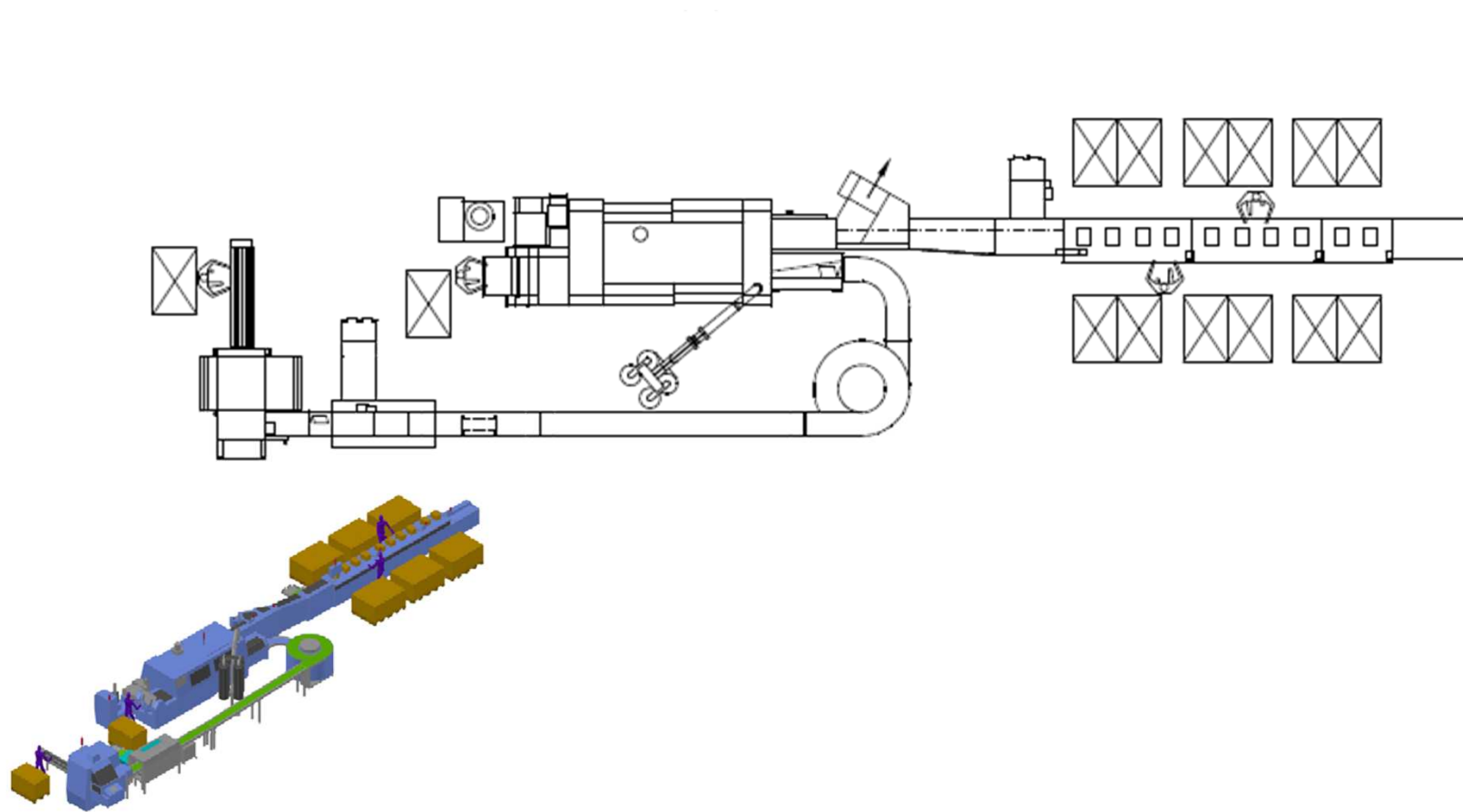



Key features at a glance – Modular Design.

Modularity and flexibility in perfection

- ▶ Pantera – inline with gathering machine 3692 and three-knife trimmer Granit and lose book pile infeed for hybrid-operation (Digital and Offset).

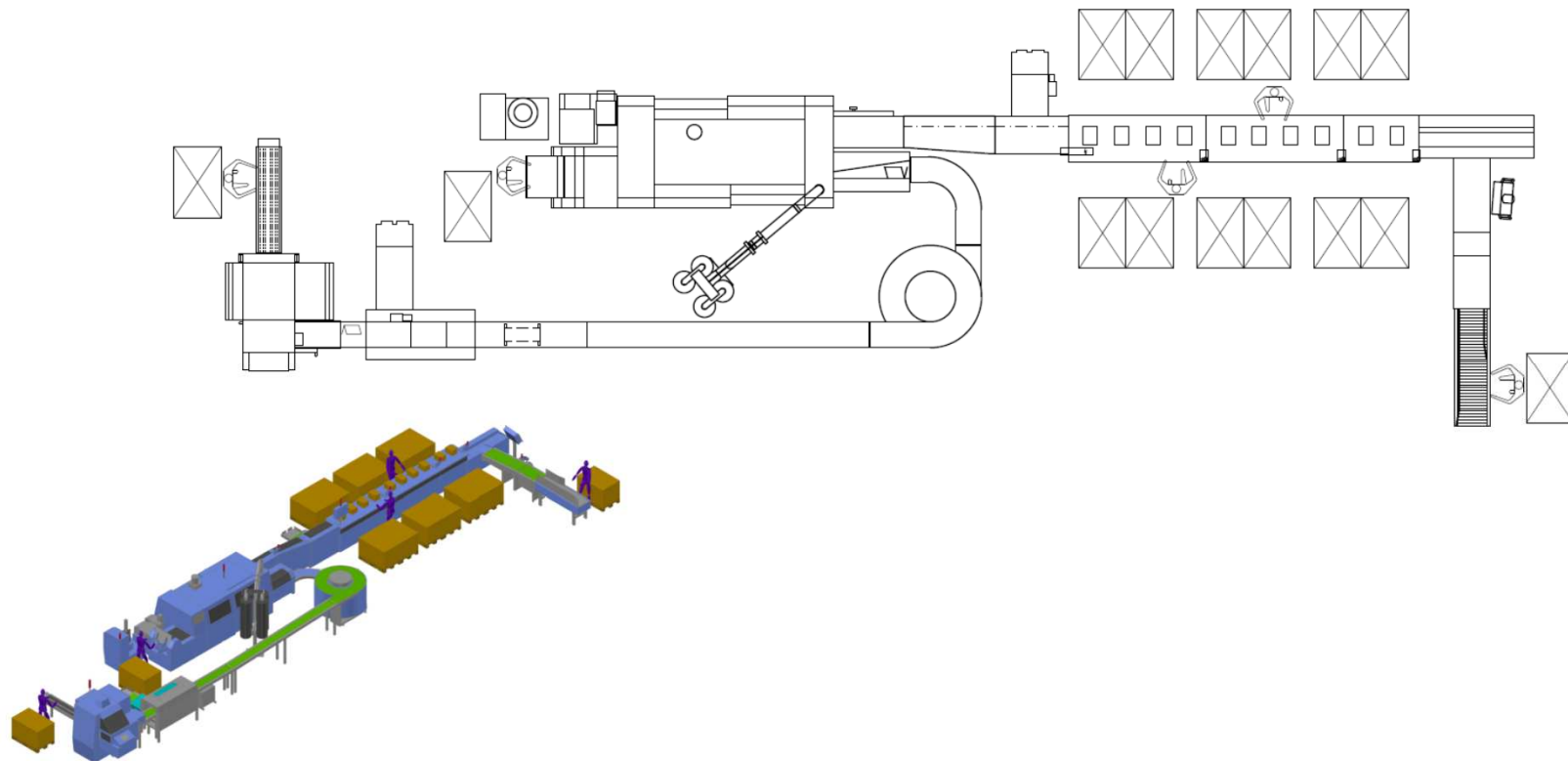



Key features at a glance – Modular Design.

Modularity and flexibility in perfection

- ▶ Pantera – **Upgrade to the Alegro MC platform** in-line with existing gathering machine 3692 and existing three-knife trimmer Granit.
- ▶ **Maximal investment protection!**

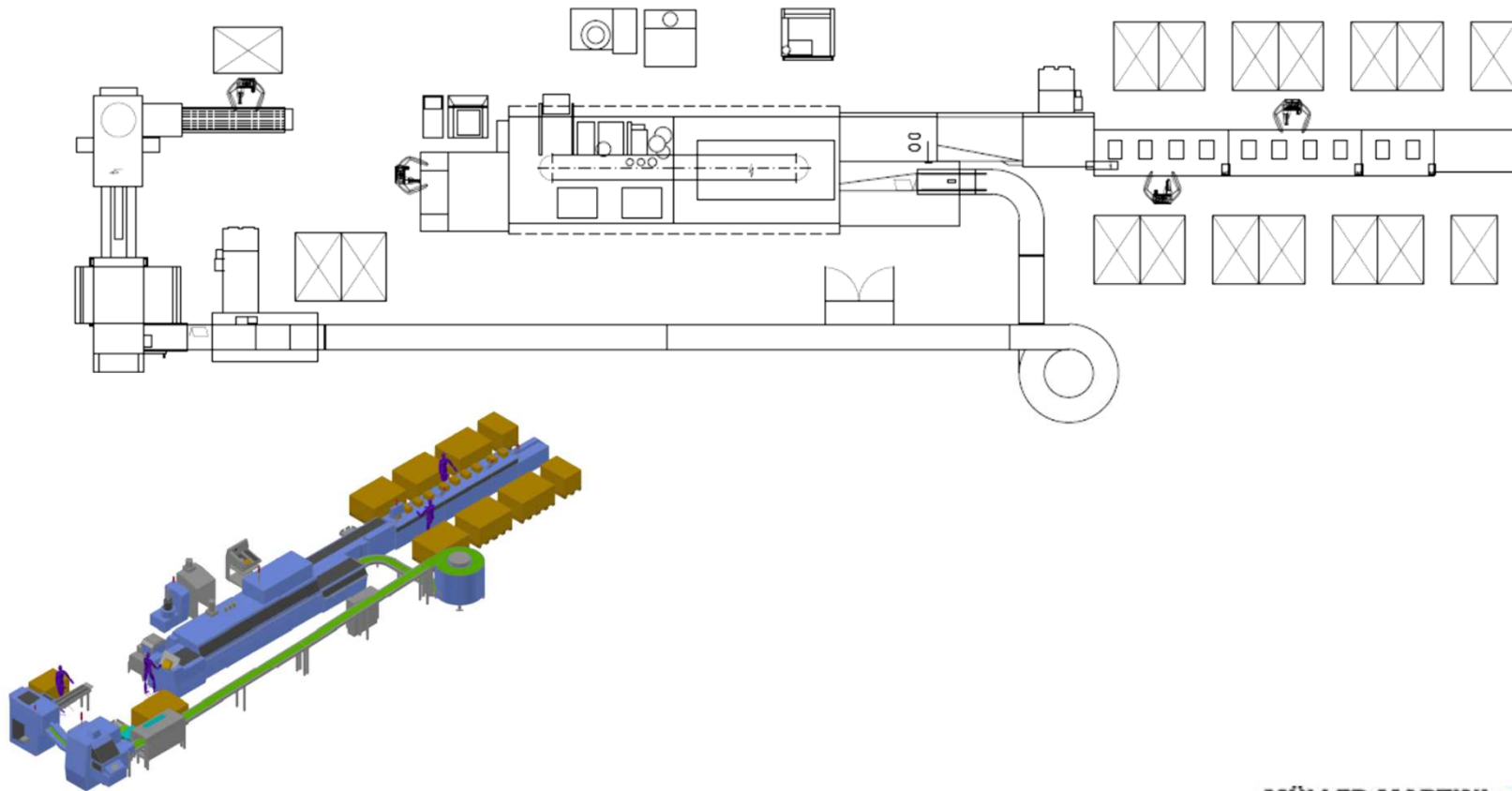



Key features at a glance – Modular Design.

Modularity and flexibility in perfection

- ▶ Pantera – Inline with gathering machine 3692 and Three-Knife Trimmer Granit complete for Hotmelt- and PUR Production and processing of digital book blocks via lose pile infeed 3720.

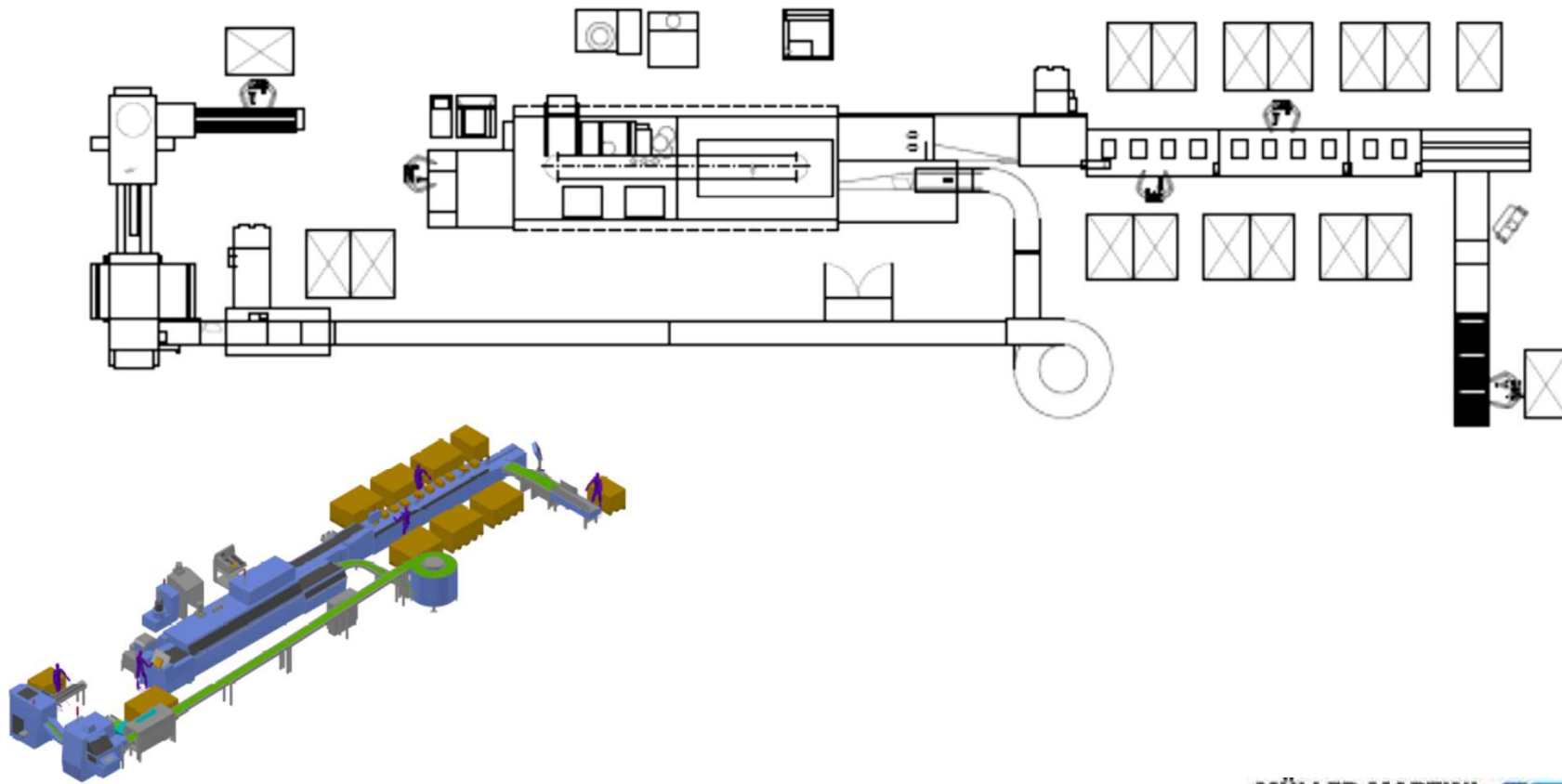



Technical specification.

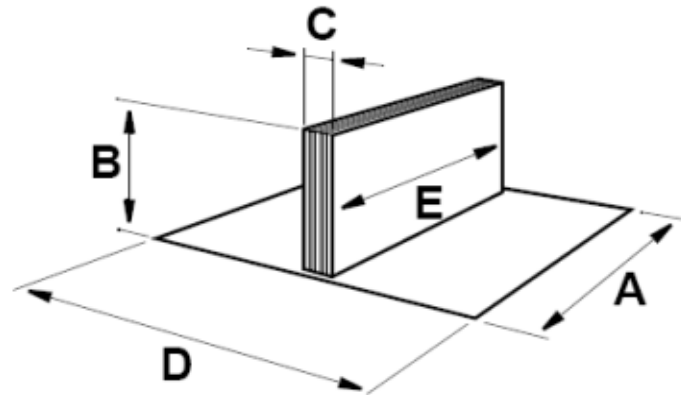

Maximal mechanical speed	4000 c/hr
Number of clamps	9
Spine length – E	120 - 380 mm
Book width – B	100 - 320 mm
Book thickness – C	2 - 50 mm
Cover length – A	120 - 390 mm
Cover width – D	202 - 640 mm
Weight content	60 - 170 g/m ²
Weight cover	80 - 350 g/m ²
Milling depth	0 - 4 mm



Your strong partner.

Müller Martini. Your strong Partner.

High-Quality System Solutions and First-Class Services for the Graphic Arts Industry. Cutting-Edge Technology. A Global Presence.

Thank you for your attention.

MÜLLER MARTINI

